

# Relax Suite

Classy chaise longue electrically adjustable by means of 2 electric actuators. Its quilted padding, made of a multilayer foam with different densities, perfectly matches with the **SPA Suite** table.

Customer can select the most comfortable position through a practical hand set control.

Available in more than 50 colors. It's standard with a useful table-holder.

**Suite Stools** in the same style complete the cabin.

*Lussuosa chaise longue regolabile elettricamente mediante 2 motori elettrici. L'imbottitura capitonné, realizzata con gomma indeformabile di varie densità, si abbina perfettamente al lettino **SPA Suite**.*

*Una pratica pulsantiera permette al cliente di regolare la posizione autonomamente.*

*Disponibile in oltre 50 colori. Standard con un comodo tavolino di appoggio.*

*Gli **Suite Stools** nello stesso stile completano la cabina.*

**Lemi**<sup>®</sup>  
MADE IN ITALY



**100%**  
made in italy

# Technical specifications

## Specifiche Tecniche

Table of dimensions / *Tabella dimensionale*

Relax Suite cod. 168 W



N° 443.090.V

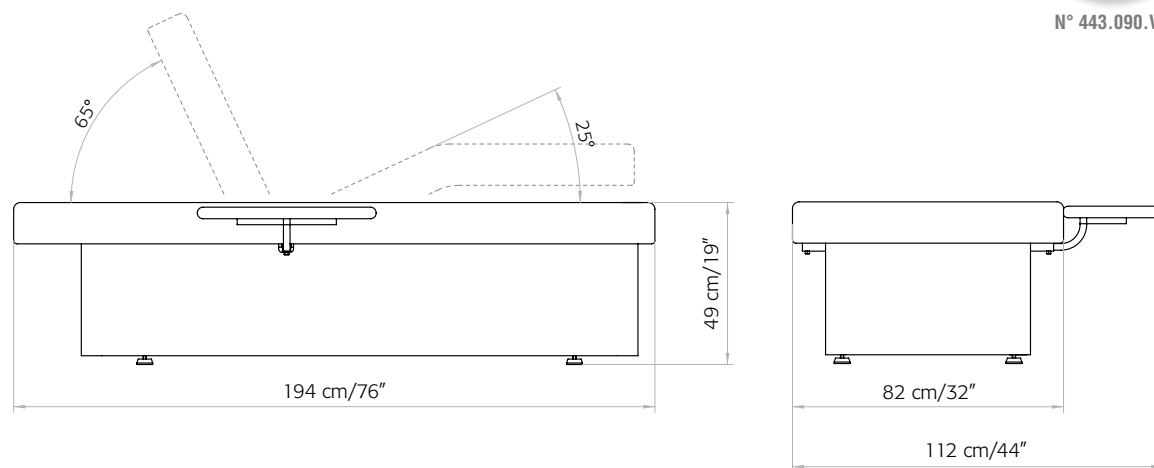

Options upon request  
*accessori su richiesta*

heating system/*materasso riscaldato*  
cod. 180 S2

color therapy/*cromo terapia*: cod. KIT CROMO

kit sound: cod. KIT SOUND



### Packaging details

#### *Caratteristiche imballo*

Sizes / *Dimensioni*: cm 203x82x81 h (80"x32"x32")

Volume: 1,35 m<sup>3</sup>

Gross weight / *Peso lordo*: 120 kg (265 lbs)

Net weight / *Peso netto*: 94 kg (207 lbs)

### Warranty / *Garanzia*

Structure 10 years / *Struttura 10 anni*

Motors e controls 2 years / *Motori e comandi 2 anni*

Cushion 5 years / *Imbottitura 5 anni*

Heating 1 year / *Riscaldamento 1 anno*

### Electric requirements

#### *Caratteristiche elettriche*

Voltage / *Voltaggio*: 230/110V ac

Frequency / *Frequenza*: 50/60 Hz

Absorption / *Assorbimento*: 1 A max

Relax Suite is CE conformed and is manufactured in accordance with European Directives: 2006/42/CE ; 2006/95/CE; 2004/108/CE.

*Relax Suite è a norme CE ed è fabbricato in conformità alle seguenti Direttive Europee: 2006/42/CE; 2006/95/CE; 2004/108/CE.*



**Brusaferrì & C S.r.l.**

Headquarters / *Sede operativa*:

via M. Maretti Soldi, 13 (ex S.P. n. 6)

26011 Casalbuttano (CR) • Italy

Tel. +39 0374 363068/69

Fax +39 0374 363071

[www.lemi.it](http://www.lemi.it) • [info@lemi.it](mailto:info@lemi.it)

